

brother.

OPERATION MANUAL

•
**Model
XL2010**
•

CAUTION

When leaving the sewing machine unattended, the power supply plug must be removed from the outlet. When servicing the sewing machine, removing covers or changing the bulb, the machine or electrical set must be disconnected from the power supply by removing the plug from the outlet.

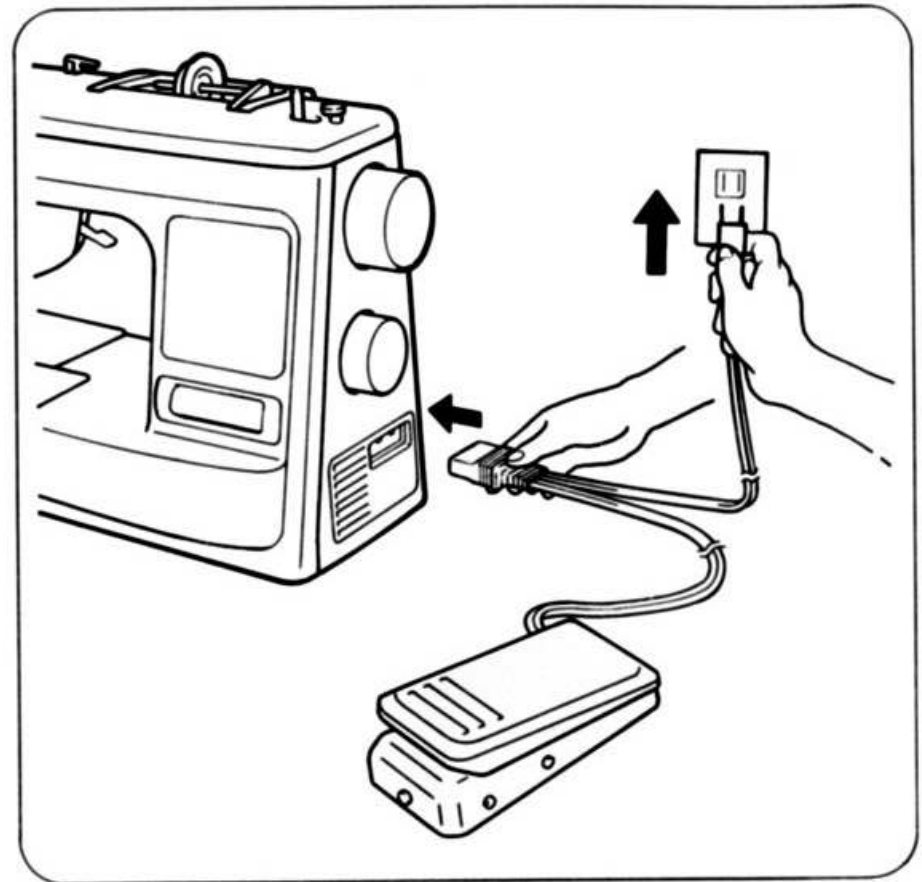

CONTENTS

	Page		
KNOWING YOUR SEWING MACHINE	1		
Principal parts	1		
Accessories	2		
VARIOUS CONTROLS	3		
Pattern selector	3		
Stitch length dial	5		
Reverse sewing button	5		
Foot controller	5		
Sew-light	5		
Free-arm model	6		
Twin needle	6		
THREADING THE MACHINE	7		
Winding the bobbin	7		
Lower threading	8		
Upper threading	9		
To draw up lower thread	10		
Tension controls	11		
RELATIVE CHART OF SEWING FABRICS, NEEDLE AND THREAD	12		
STRAIGHT AND ZIGZAG STITCHING	13		
Straight stitch	13		
Zigzag stitch	15		
BUILT-IN STITCHES	16		
Blind hem stitch	16		
Overedging stitch	17		
Elastic stitch	18		
BUTTONHOLE AND BUTTON SEWING	19		
Buttonhole	19		
Button sewing	21		
USING ATTACHMENTS AND APPLICATIONS	22		
Zipper insertion	22		
Darning	23		
Applique	23		
Monogramming and Embroidering	24		
MAINTENANCE	25		
Changing the needle	25		
Changing the bulb	26		
Cleaning	27		
Oiling	28		
Performance check list	29		
Repacking the machine	31		
INDEX	32		

KNOWING YOUR SEWING MACHINE

Principal parts

- ❶ **BOBBIN WINDER DEVICE**
Winds the lower thread onto the bobbin.
- ❷ **SPOOL HOLDER**
- ❸ **STITCH LENGTH DIAL**
Controls the feed of stitches.
- ❹ **PRESSER FOOT LEVER**
- ❺ **UPPER TENSION CONTROL DIAL**
Controls the upper tension.
- ❻ **EXTENSION TABLE & ACCESSORIES COMPARTMENT**
- ❼ **PATTERN INDICATION PANEL**
- ❽ **REVERSE SEWING BUTTON**
Push for reverse stitching.
- ❾ **BALANCE WHEEL**
Turn toward you to lower and raise the needle.
- ❿ **CLUTCH RELEASE KNOB**
- ⓫ **PATTERN SELECTOR**
Turn in any direction to select the desired stitch.
- ⓬ **FOOT CONTROLLER RECEPTACLE**
Insert the foot controller plug for operation.
- ⓭ **FOOT CONTROLLER**

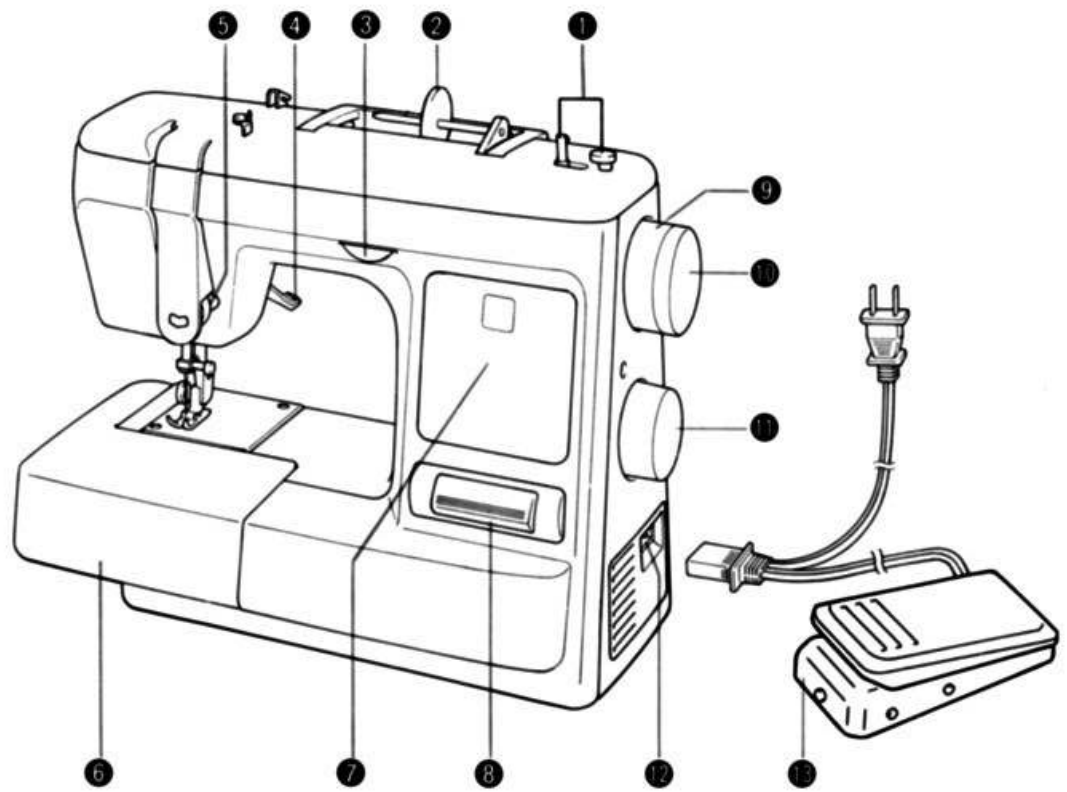

Accessories

- | | |
|-------------------------------------|----------------------|
| ① Buttonhole & Button Sewing | 1 pc. (Page 19 – 21) |
| ② Zipper Foot | 1 pc. (Page 22) |
| ③ Needle Pack | 1 set |
| (Regular Single Needle No. 14 | 3 pcs.) |
| (Twin Needle | 1 pc.) |
| ④ Bobbin | 3 pcs. (Page 7) |
| ⑤ Darning Plate | 1 pc. (Page 23) |
| ⑥ Screw Driver (Large & Small) | 2 pcs. (Page 25, 26) |
| ⑦ Extra Spool Pin | 1 pc. (Page 6) |
| ⑧ Spool Holder (Large & Small) | 2 pcs. (page 7, 9) |

The above accessories are stored in the accessory compartment under the extension table. These accessories have been designed for easy and perfect sewing. For more details, see each page listed.

Accessory compartment

Lift the extension table up and slide it out.
Then draw the accessory compartment down pushing its underside.

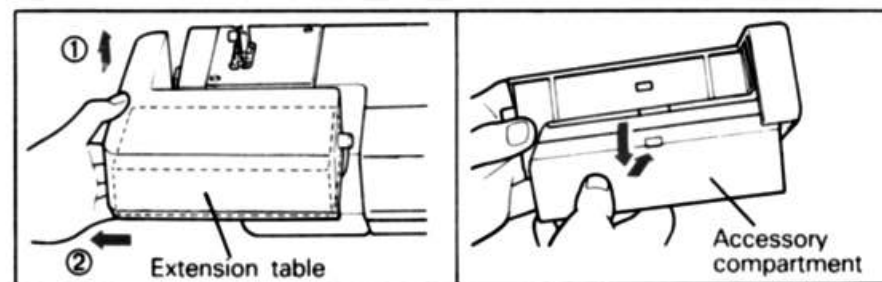
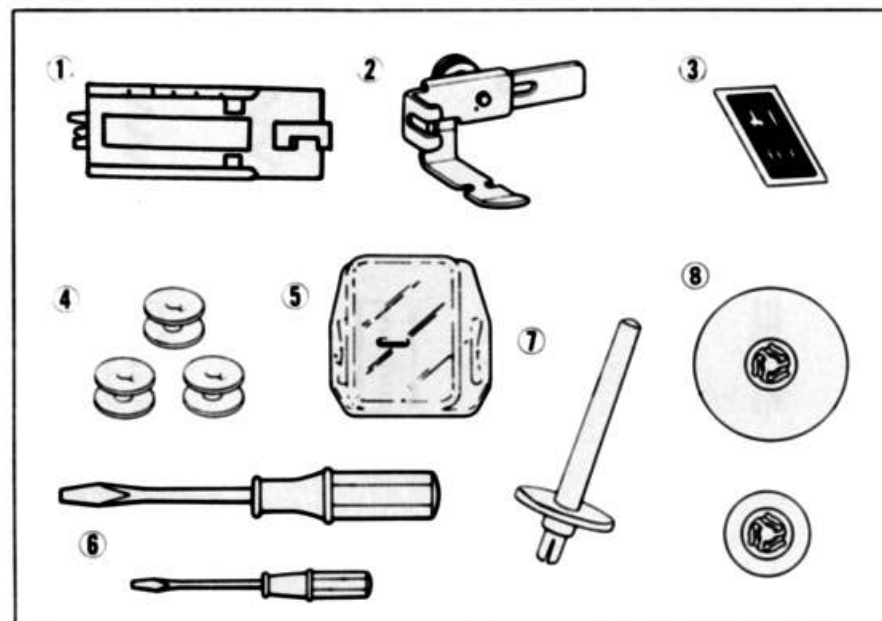

VARIOUS CONTROLS

Pattern selector

To select a stitch, simply turn the pattern selector located on the end of the machine. All stitches are preset in width, therefore, the stitch length is the only adjustment. The following table represents the preset width of each stitch and the recommended range of stitch length.

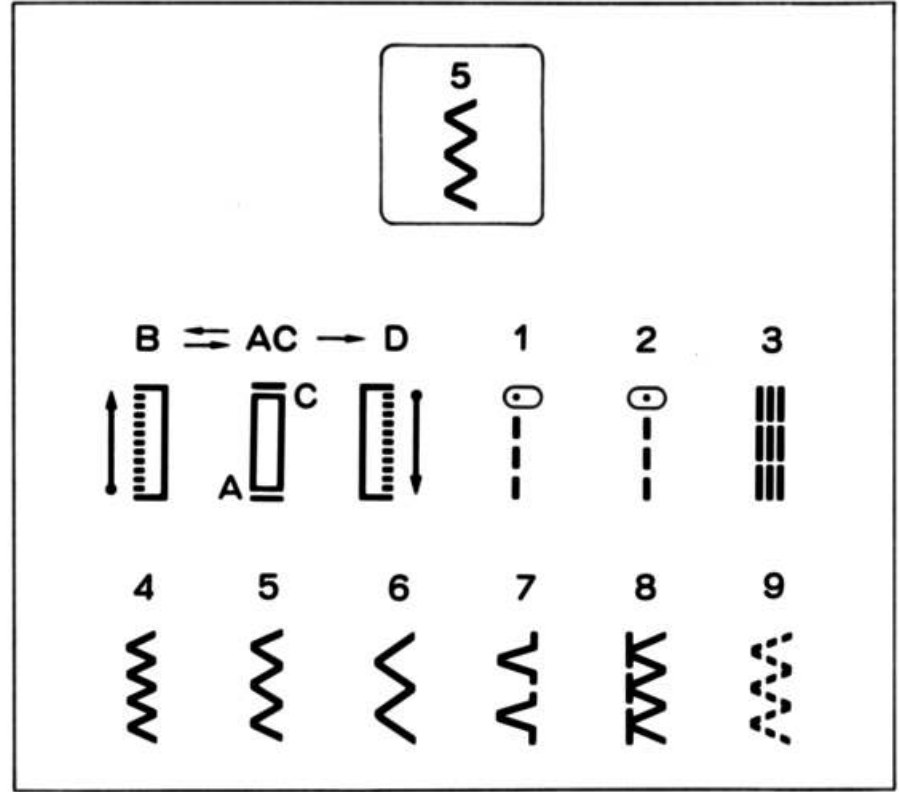
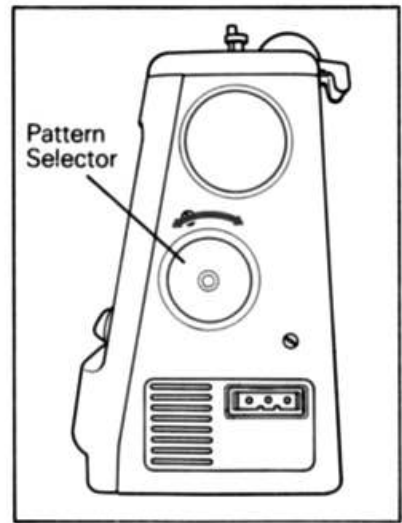

RECOMMENDED LENGTH

PATTERN	STITCH NAME	PRE SET WIDTH (MM)	RECOMMENDED LENGTH (MM)	PAGE
A-B-C-D	Automatic Buttonhole	4.8	F-3	19
1	Straight Stitch (Left needle position)	0	F-4	13
2	Straight Stitch (Center needle position)	0	F-4	13
3	Stretch Straight Stitch	0	4	13
4	Zigzag Stitch	1.6	F-4	15
5	Zigzag Stitch	3.6	F-4	15
6	Zigzag Stitch	4.8	F-4	15
7	Blind Hem Stitch	3	1-2	16
8	Elastic Overlock	4.8	4	17
9	Elastic Stitch	4.8	1-2	18

Stitch length dial

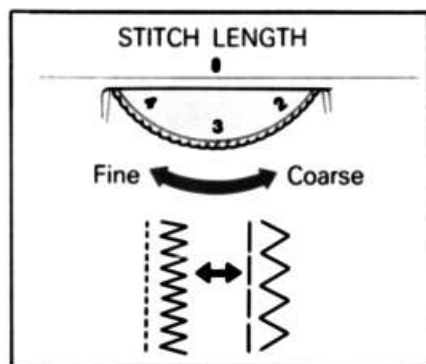

Depending on the stitch selected, you may need to adjust the stitch length. The numbers marked on the dial represent the stitch length. **THE HIGHER THE NUMBER, THE LONGER THE STITCH.** The "0" means the material does not feed. The "F" area is used for making a SATIN stitch (closed stitch) for buttonhole and decorative stitches.

Reverse sewing button

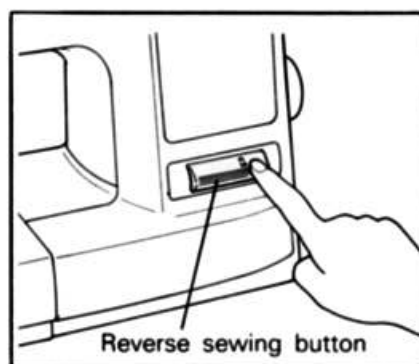

To sew in reverse, push the button as far as it goes. Hold the button in this position until you wish to sew forward. When the button is released, it will spring back in original position and the machine will sew forward. Reverse sewing is used for back-tacking and reinforcement of seams.

Foot controller

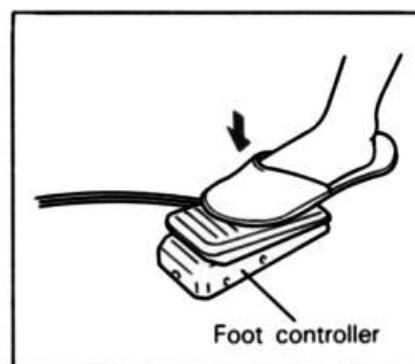

When the foot controller is depressed lightly, the machine will run at a low speed. When the pressure on the foot controller is increased, the machine will pick up the speed. When the foot controller is released, the machine will stop. Care should be taken that nothing is placed on the foot controller when the machine is not in use.

Sew-light

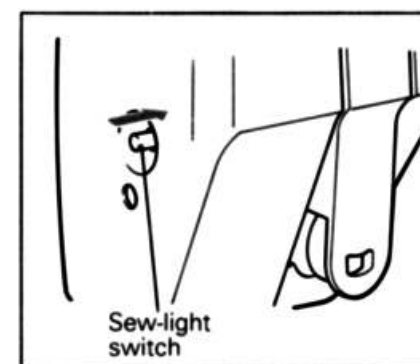

To turn the sew-light on or off, push the sew-light switch.

Free-arm model

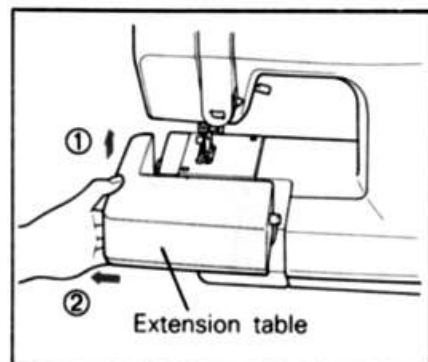

For sewing tubular and hard-to-reach garment areas, free-arm sewing is convenient. To change your machine to a free-arm model, simply lift the extension table then slide it out.

Twin needle

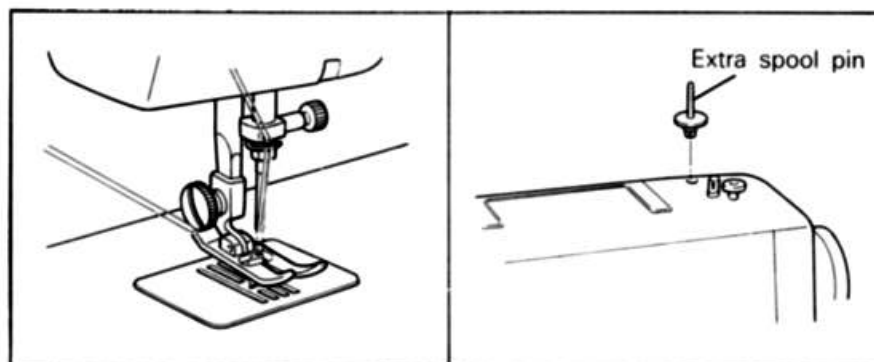

Your sewing machine is designed for twin needle sewing with Straight Stitch (Center) and Stretch Straight Stitch.

INSERTING TWIN NEEDLE

Insert the twin needle in the same manner as single needle.

THREADING TWIN NEEDLE

Set the extra spool pin into a hole on the top of the machine. Follow the instructions for single needle threading (See page 9), but thread each needle separately.

THREADING THE MACHINE

Winding the bobbin

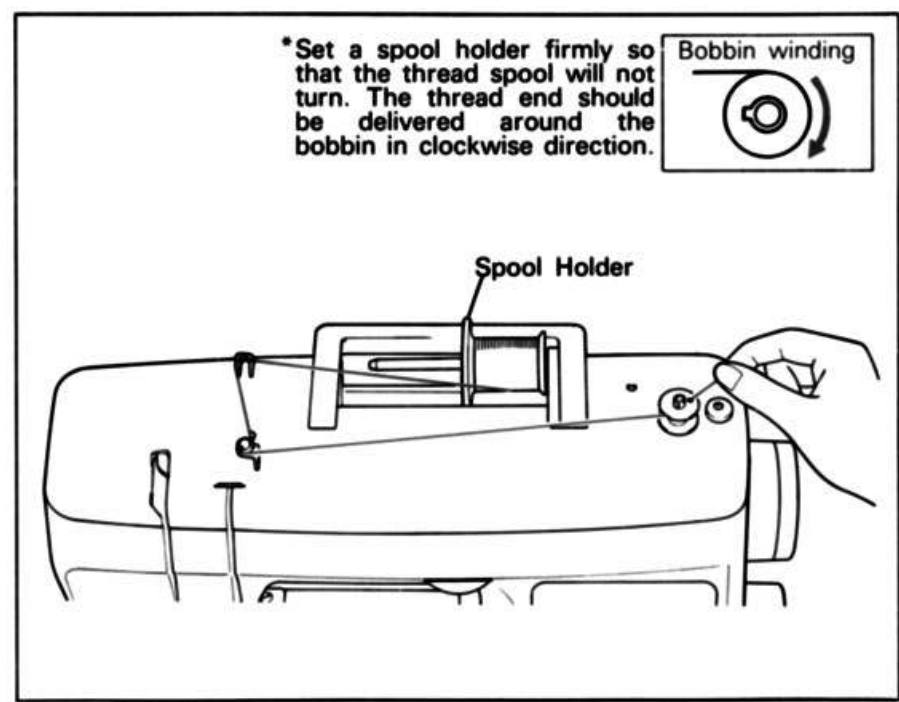

1. Deliver thread through the thread-guides as illustrated.

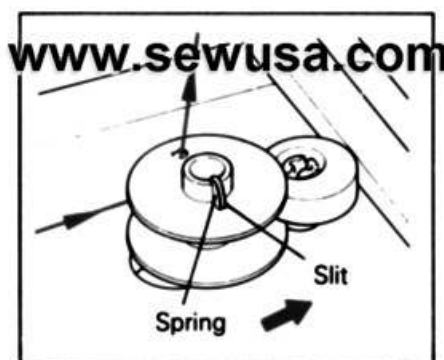

2. Holding the thread end, push the bobbin winder shaft to the right.

*The slit on the bobbin should match with the spring on the shaft.

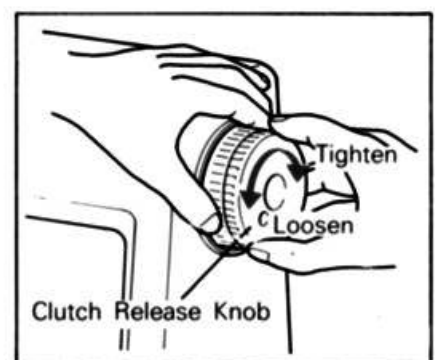

3. Loosen the Clutch Release Knob by turning toward you.

Lower threading

Winding the bobbin (CONTINUED)

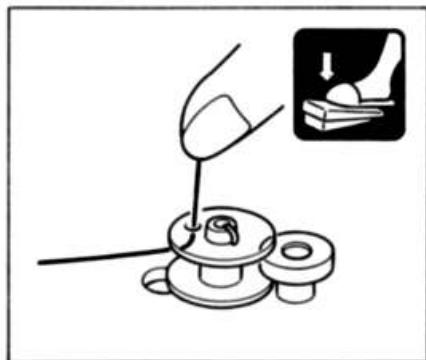

4. Holding the thread end, depress the foot controller to wind the thread. The machine stops automatically when the bobbin is full.

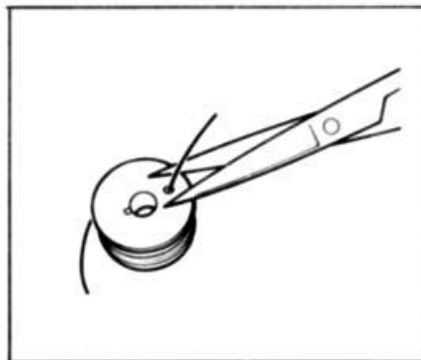

5. Push the shaft to the left. Remove the full bobbin from the shaft, and trim the excess thread. Tighten the clutch release knob securely.

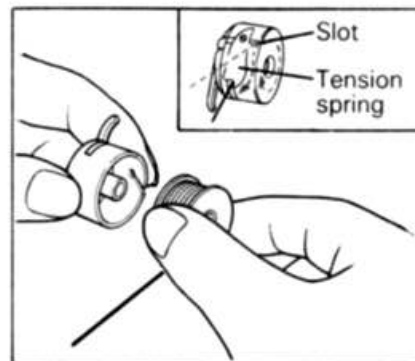

6. Unwind about 4 inches (10 cm) from the bobbin, and insert the bobbin into the bobbin case. Pull the trailing thread into the slot, down and to the left until it enters the delivery eye under the tension spring.

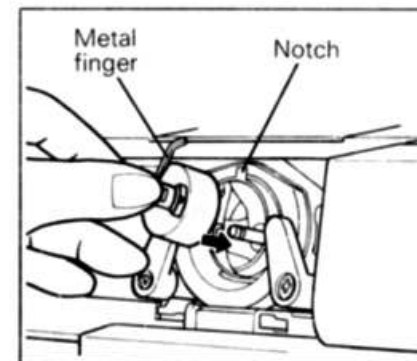

7. Holding the bobbin case latch, insert the bobbin into the shuttle race. Make sure to fit the metal finger into the notch at the top of race.

Upper threading

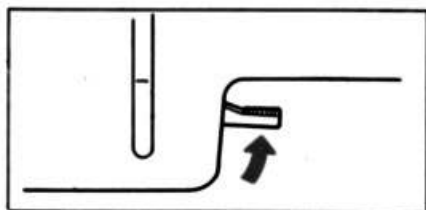

1. Raise the presser foot lever.
2. Raise the needle to its highest position by turning the balance wheel toward you.

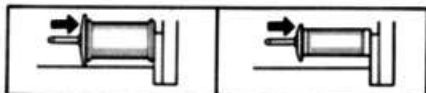

3. Place a thread spool on horizontal spool pin.
4. Choose an appropriate spool holder according to type and diameter of spool being used. (The diameter of spool holder should be larger than that of the spool itself)
5. Press the spool holder firmly to the spool.

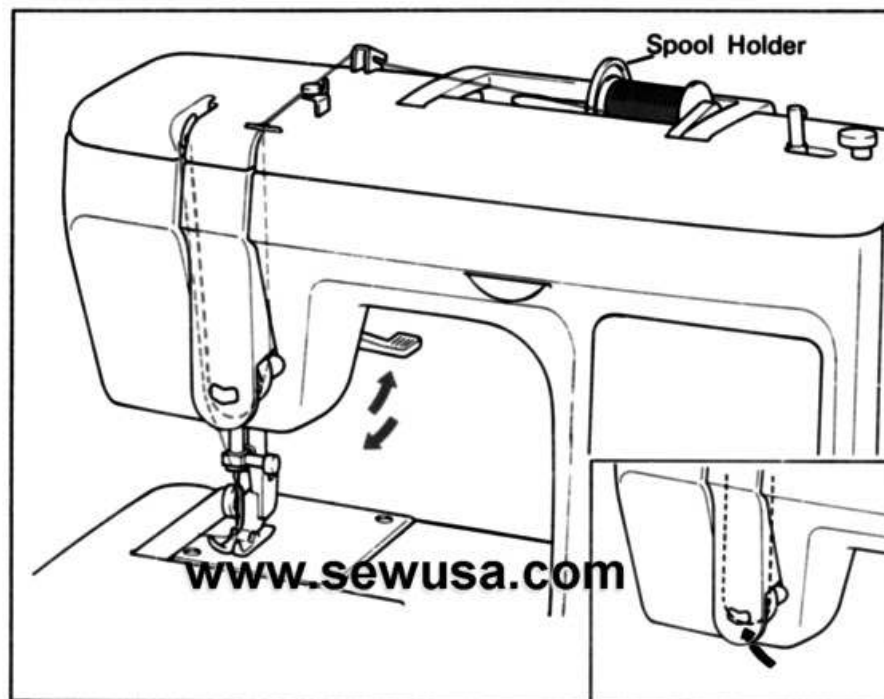

6. Deliver the upper thread as illustrated.

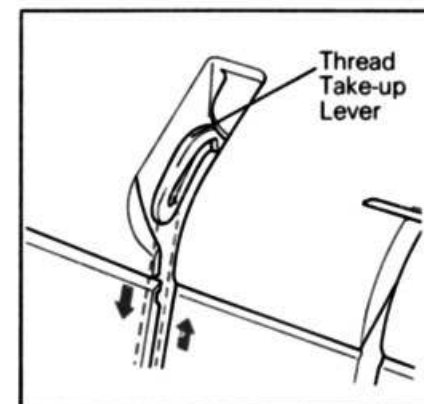

7. Make sure to guide the thread through thread-take-up lever from right to left.

To draw up lower thread

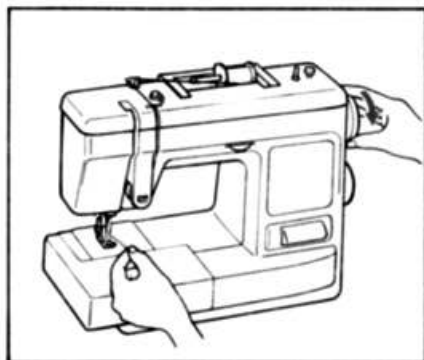

1. Raise the needle and the presser foot to the highest position. With left hand, hold the end of upper thread and with right hand, turn balance wheel toward you until the needle moves down and up again to its highest position.

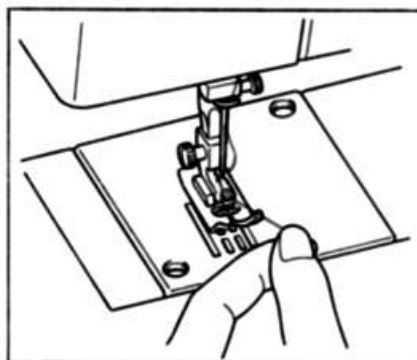



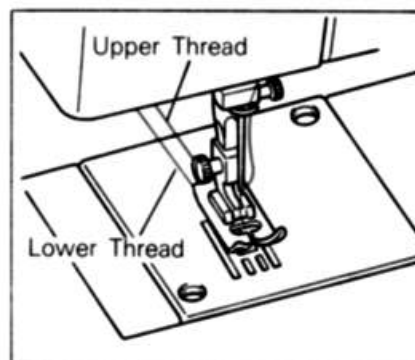

2. The upper thread has caught the lower thread in a loop. Pull the upper thread toward you and the lower thread will come up from the bobbin in a large loop.

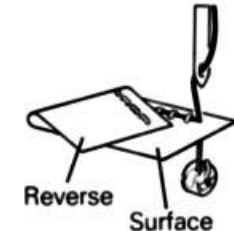

3. Pull about 4 inches (10 cm) of thread under the toe of the presser foot toward the back of the machine.

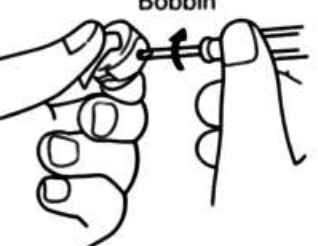
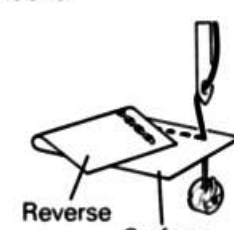
Tension controls

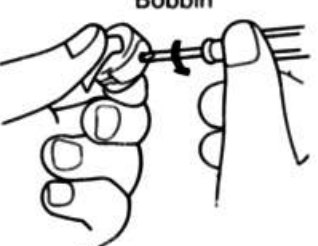
<p>■ Upper tension is too tight. Locks appear on the fabric surface.</p> 	→	<p>Upper Tension Dial Decrease tension Lower number.</p> 	← or →	<p>Bobbin</p>  <p>Increase tension</p>
<p>■ Upper tension is too loose. Locks appear on the reverse side of the fabric.</p> 	→	<p>Upper Tension Dial Increase tension. Raise number.</p> 	← or →	<p>Bobbin</p>  <p>Decrease tension</p>

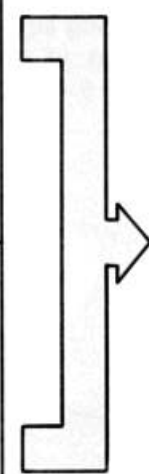

Correct tension

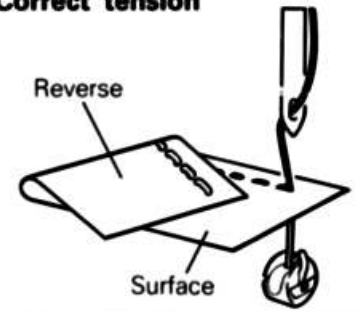

Correct tension is important because too much or too little tension will weaken your seams or cause puckers on your fabric.

RELATIVE CHART OF SEWING FABRICS, NEEDLE AND THREAD

SEWING MATERIALS		NEEDLE SIZES	THREAD SIZES
VERY THIN	Fine tricot, Fine lace, Thin linen, Silk, Tulle, Chiffon	9	Cotton: 80 Synthetic Fine Mercerized Cotton
LIGHTWEIGHT	Organdy, Jersey, Voile, Taffeta, Synthetics, Silk, Batiste	11	Cotton: 60 - 80 Silk: "A" Synthetic Mercerized 50
MEDIUM	Cotton, Gingham, Poplin, Percale, Pique, Satin, Velvet, Lightweight wool, Fine corduroy, Suitings	14	Cotton: 50 - 60 Silk: "A" Synthetic Mercerized 50 - 60
HEAVY	Denim, Gabardine, Tweed, Corduroy	16	Cotton: 40 - 50 Mercerized Heavy Duty

NOTE:

1. Select the correct needle and thread size from the above chart.
2. Use the same size thread for the upper and lower threads.

STRAIGHT AND ZIGZAG STITCHING

Straight stitch

Pattern	Stitch Length
1 (Left needle position)	1-4
2 (Center needle position)	
3 (Stretch Straight Stitch)	4

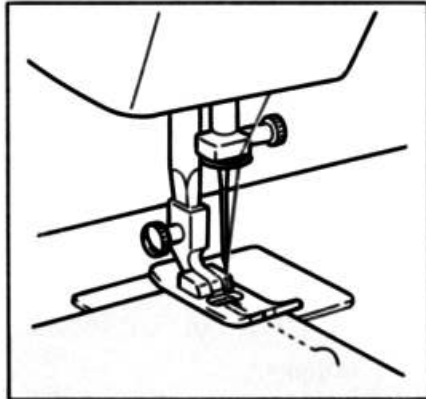

How to Start Sewing

1. Raise the needle to its highest position and lift the presser foot.

2. Pull up the lower thread by turning the balance wheel toward you and pull both upper and lower thread to the back of presser foot.
3. Place fabric under the presser foot and position needle 5/8 inch (10 mm) beyond fabric edge.
4. Lower the presser foot.
5. To back tack, push the Reverse Sewing Button as far as it goes. Reverse sewing is used for locking end of seam and where reinforcement is needed.
6. Release the Reverse Sewing Button and start sewing in forward direction.

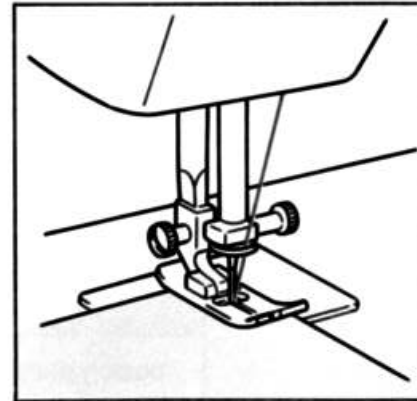

How to Change Sewing Direction

1. Stop the machine at the turning point while the needle is in the fabric.
2. Raise the presser foot and turn the fabric to its new direction while the needle acts as the axis.
3. Lower the presser foot and start sewing in new direction.

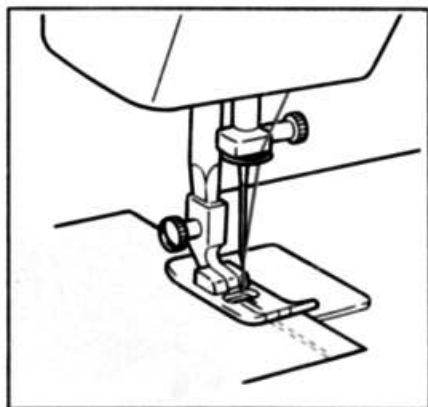

How to Finish Your Sewing Project

Reverse stitching is used to lock the threads at the end of the seam or wherever reinforcement is needed.

1. This is done by stitching to the end of the seam. Then stop.
2. Push the Reverse Sewing Button and stitch backward for 3/8 inch (10 mm) from end of the seam fabric.



How to Remove from Machine

1. Stop the machine.
2. Raise the needle to its highest position and make sure that the thread take-up lever is also in the highest position.

3. Lift the presser foot and pull out the fabric gently to the left side.

4. Cut both threads by the thread cutter equipped with the machine.

5. To prepare the machine for the next seam, pull 4 inches (10 cm) of thread between the toe of the presser foot toward the back of the machine.

Top Stitching and Stretch Materials

No. 1 (Left needle position) is used for Top stitching and sewing light weight fabrics.

No. 3 (Stretch Straight Stitch) is for stretchable fabrics.

Zigzag stitch

Pattern	Stitch Length
4 (Stitch Width at 1.6 mm)	F-4
5 (Stitch Width at 3.6 mm)	
6 (Stitch Width at 4.8 mm)	

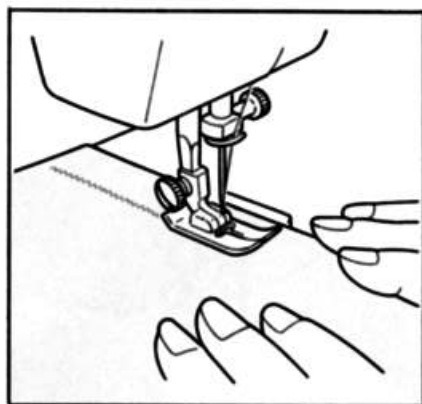

SIMPLE ZIGZAG STITCHING

Select the Pattern number depending on the width you need and select the stitch length. It is recommended to sew the straight stitch at the beginning and end of zigzag stitches.

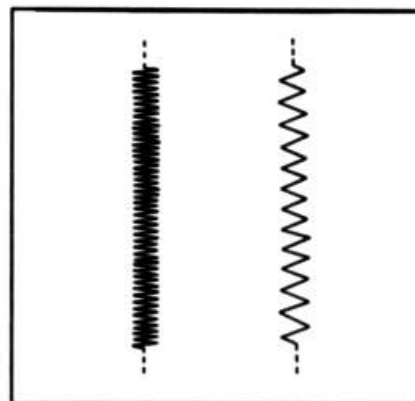

SATIN STITCH

When stitch length is set at "F" position, it produces the "SATIN STITCH" used for making button-holes or decorative stitches.

BUILT-IN STITCHES

Blind hem stitch

Pattern	Stitch Length
7 (Blind Hem Stitch)	1-2

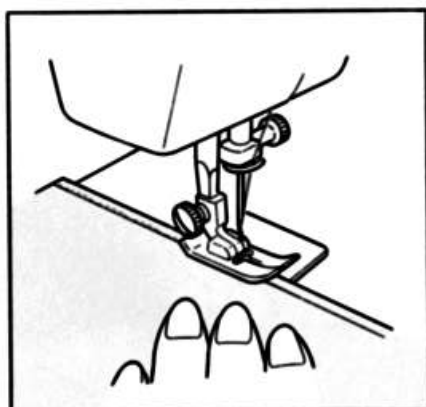

1. Thread used should be the same color as the fabric used.
2. Fold the fabric to the size of hem desired and then fold back as shown in Figure A. Leave 1/4 inch overlap at edge.
3. Sew on the fold as in Figure B.
4. When the fabric is unfolded you will have a blind stitch hem as in Figure C.

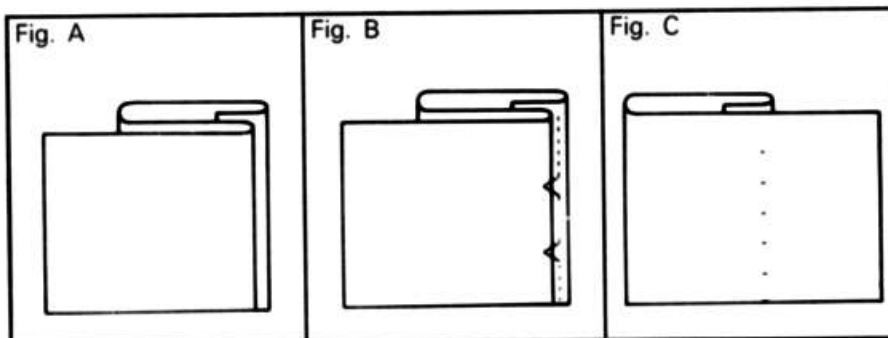

Overedging stitch

Pattern	Stitch Length
8 (Elastic Overlock Stitch)	4

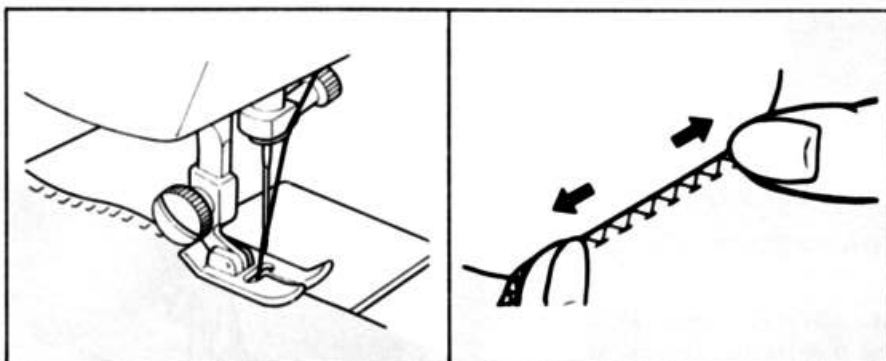

Position the fabric under the presser foot so the right (zigzag) side of the stitch pattern forms along the cut edge of the fabric. The left hand (straight stitch pattern) forms the seam stitching line of approximately 1/4 inch seam allowance. If the seam allowance is wider than the stitch pattern, trim away any excess fabric after stitching.

Elastic stitch

Pattern	Stitch Length
9 (Elastic Stitch)	1-2

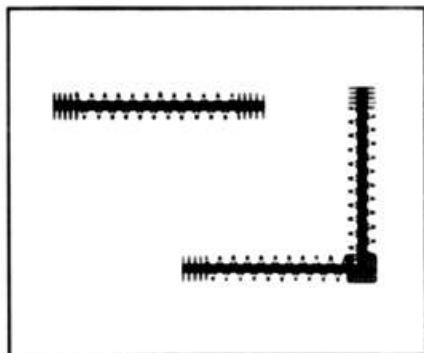

MENDING

1. Set the stitch Length Dial between F-1.
2. Place reinforcement fabric under tear.
3. Following the line of tear, sew using the elastic to join both sides of the tear.

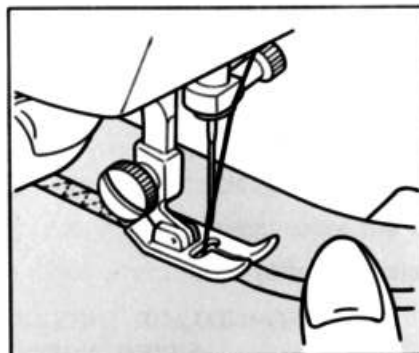

SEWING ELASTIC

1. Place the elastic on the fabric.
2. As you sew, stretch elastic both in front and in back of the presser foot as shown in illustration.

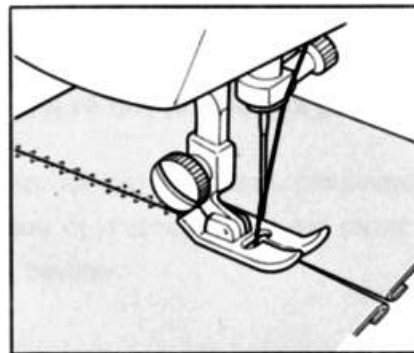

JOINING STITCH

1. The elastic stitch is used to join fabric together.
2. Place fabric edge to edge under the presser foot.
3. Sew together using elastic stitch. Care should be taken to keep the two fabric edges close together.

BUTTONHOLE AND BUTTON SEWING

Buttonhole

Pattern	Stitch Length	Foot
B AC D	F-3	Buttonhole foot

NOTE: It is a good idea to practice making a buttonhole on a scrap of fabric before attempting the actual garment.

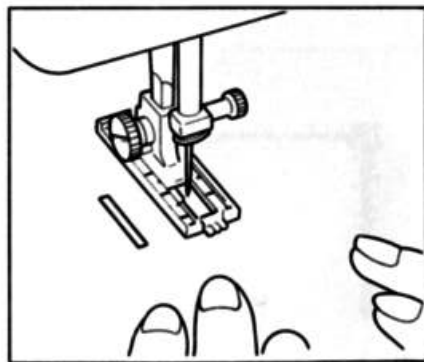









Automatic buttonhole making is a simple process that provides reliable results.

MAKING BUTTONHOLE

1. Use buttonhole foot with sliding portion.
2. Using tailor chalk, mark the position of buttonhole on the fabric.
3. Attach the buttonhole foot and push its sliding portion backward until it stops.
4. Place the fabric under the presser foot so that front end of bar tack can be sewn first.

PROCEDURE OF MAKING BUTTONHOLE

Step	Sewing portion	Pattern	How to sew
Step A (Front end of bar tack)	 A		<ol style="list-style-type: none"> 1. Set the pattern at A. 2. Lower presser foot and sew 5 to 6 stitches. 3. Stop machine and raise needle from the material.
Step B (Left side row)	 B		<ol style="list-style-type: none"> 1. Turn the pattern selector and set at B. 2. Sew predetermined length. 3. Stop machine and raise the needle.
Step C (Back end of bar tack)	 C		<ol style="list-style-type: none"> 1. Turn the selector and set at C (same position as A). 2. Sew 5 to 6 stitches. 3. Stop machine and raise the needle.
Step D (Right side row)	 D		<ol style="list-style-type: none"> 1. Set at D. 2. Sew the right side row until the needle reaches position D.

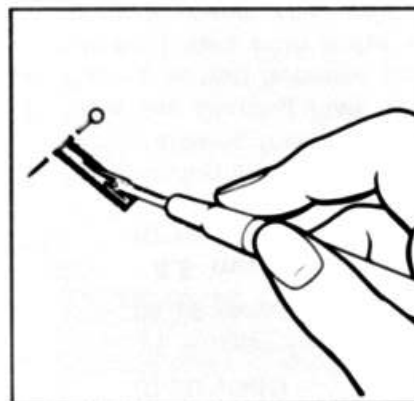

HOW TO SECURE STITCHING AND CUT MATERIAL FOR BUTTONHOLE.

1. To secure stitching, turn the material 90 degrees counter-clockwise and sew 5-6 straight stitches.
2. Remove the material from the machine. Cut opening in buttonhole with seam ripper tool. Care should be taken not to cut through any stitching.
3. It is recommended that pins are placed across both ends of buttonhole as a protection against cutting bar tack stitching.

Button sewing

Pattern	Stitch Length	Foot	Others
4 or 5 or 6	Any position	Button Sewing Foot	Darning plate

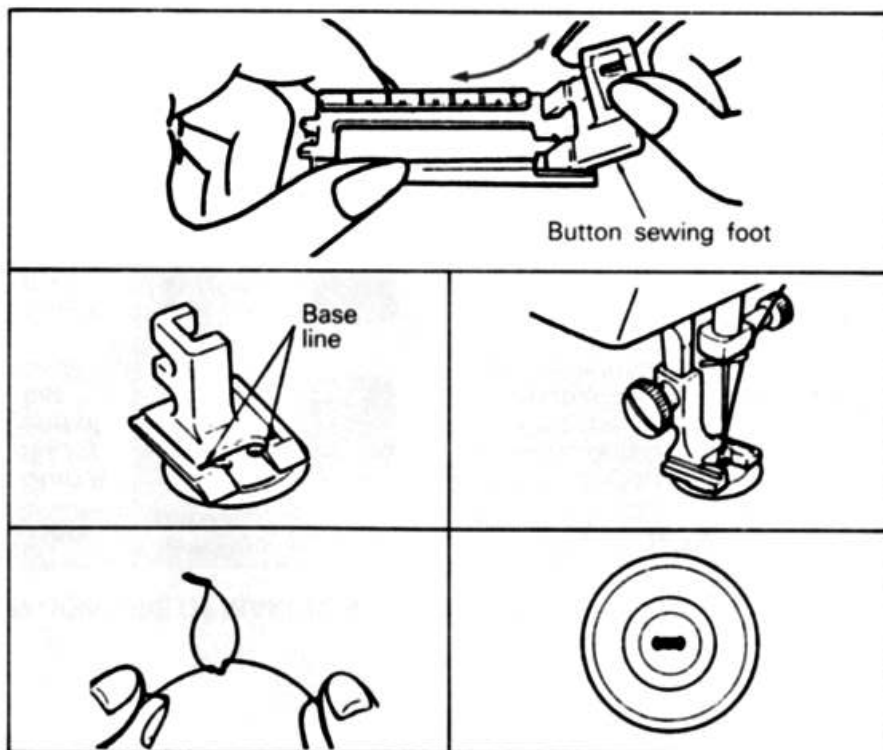

1. Measure the distance between the holes and select the Pattern.

Distance of holes	Pattern
1.6 mm (0.06 inch)	4
3.6 mm (0.14 inch)	5
4.8 mm (0.19 inch)	6

2. By removing the sliding portion of buttonhole foot, you will have a button sewing foot.
3. Place the Darning Plate on the needle plate.
4. Place a button between the foot and fabric, and make sure that needle enters both holes without hitting the button.
5. At slow speed, sew approximately 10 stitches.
6. Remove the button from the machine. Cut upper and lower threads and tie both threads at back side.

USING ATTACHMENTS AND APPLICATIONS

Zipper insertion

Pattern	Stitch Length	Foot
2	2-3	Zipper Foot

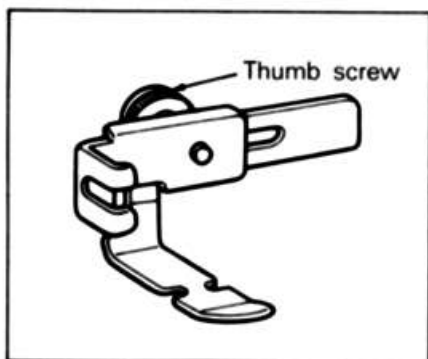

Zipper foot is used to sew various types of zippers and can easily be positioned to right or left side of needle. When zipper is sewn at right side of the needle, place the zipper foot by loosening thumb screw and sliding zipper foot to the left.

When the zipper is sewn at left side of needle, place the zipper foot by loosening thumb screw and sliding zipper foot to the right.

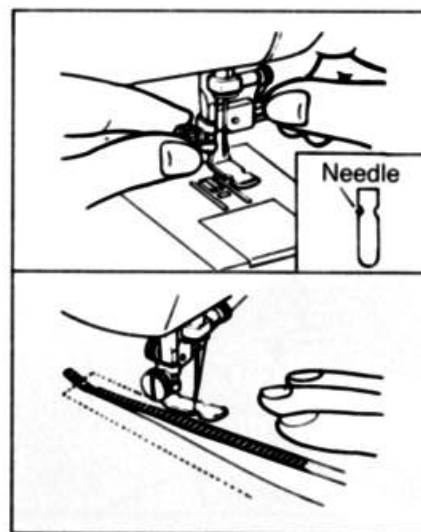

1. Lower needle into side notch located on the presser foot (right or left).
2. Tighten the thumb screw to lock presser foot into position.
3. To sew opposite side of zipper loosen thumb screw and place the zipper foot (right or left.)

Darning

Pattern Dial	Stitch Length	Others
2	Any position	Darning Plate

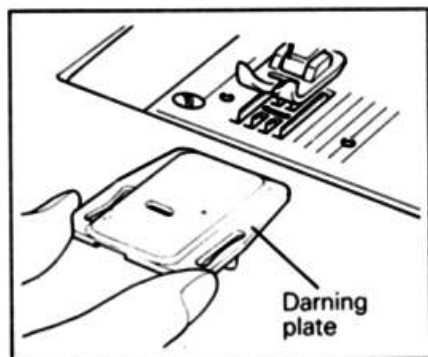

1. Set the darning plate on the needle plate as illustrated.
2. Place portion to be darned under the presser foot together with fabric underlay for reinforcement.
3. Lower the presser foot.

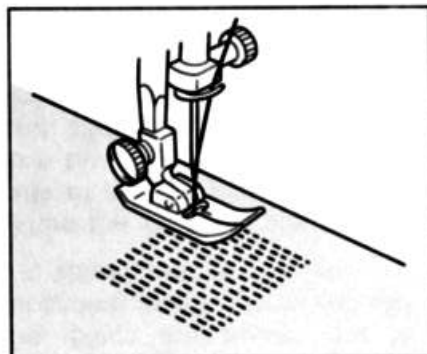

4. Sew alternately drawing the work gently away from you and pulling it toward you.
5. Repeat this motion until the portion to be darned is filled with parallel lines of stitching.

Applique

Pattern	Stitch Length
4 or 5 or 6	F-2

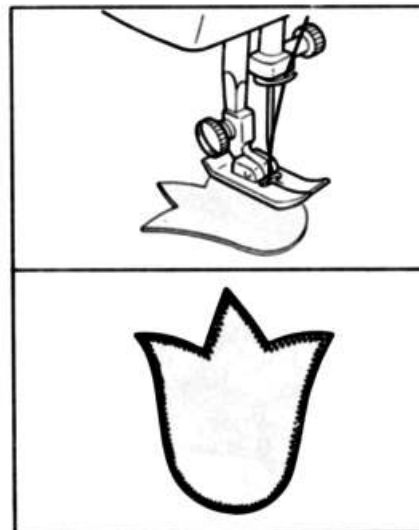

1. Baste the cut design to the fabric.
2. Sew carefully around the edge of the cutout design.
3. Cut away surplus fabric outside of stitching.
4. Remove basting.

NOTE: Make reinforcement straight stitches at beginning and the end of the stitches.

Monogramming and Embroidering

Pattern	Stitch Length	Foot	Others
4 or 5 or 6	At any position	Remove	Darning plate

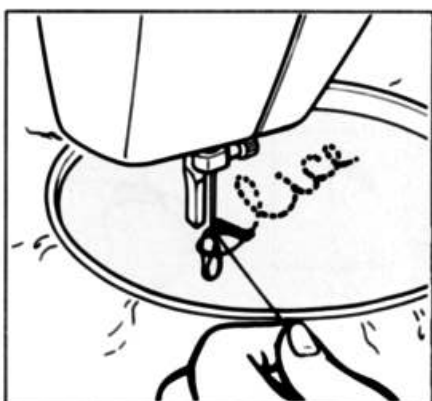

PREPARATION FOR MONOGRAMMING AND EMBROIDERING

1. Place the darning plate on the needle plate.
2. Set your sewing machine as per the above instructions.

3. Draw lettering (for monogramming) or design (for embroidering) on the right side of the fabric.
4. Stretch work between embroidery hoops as firmly as possible.
5. Place the work under the needle and lower the presser bar.
6. Pull the lower thread up through the work at starting position by turning balance wheel and make a few holding stitches.
6. Hold the hoop with thumb and forefingers of both hands while pressing the fabric with middle and third fingers and supporting the outside of hoop with smaller finger.



MONOGRAMMING

1. Sew, moving hoop slowly along the lettering at the same speed.
2. Secure with a few straight stitches.

(NOTE: These instructions also apply to embroidering.)

EMBROIDERING

1. Stitch the outline of the design by moving the embroidery hoop accordingly.
2. Fill in design stitch from the outline of the design to the inside and from inside to edge of the outline alternately until design is completely filled in. Keep stitching close together.

NOTE: A long stitch is made by moving the embroidery hoop rapidly and a short stitch is made by moving it slowly.

MAINTENANCE

Changing the needle

- Remove the power supply plug from the outlet.

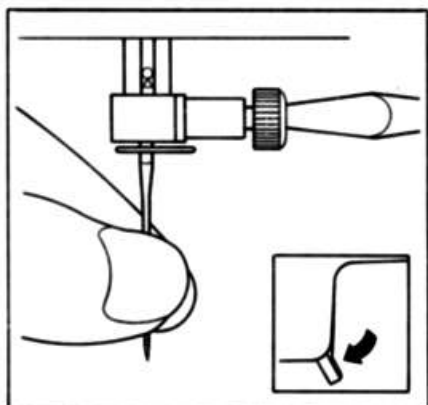

- 1. Remove the needle**
Lower the presser foot and loosen the screw.

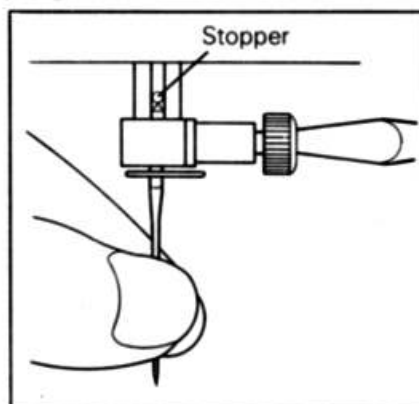

- 2. Inserting the needle**
With the flat side facing back, insert the needle as far as it will go against the needle stopper. Tighten the screw.

- How to check the needle.

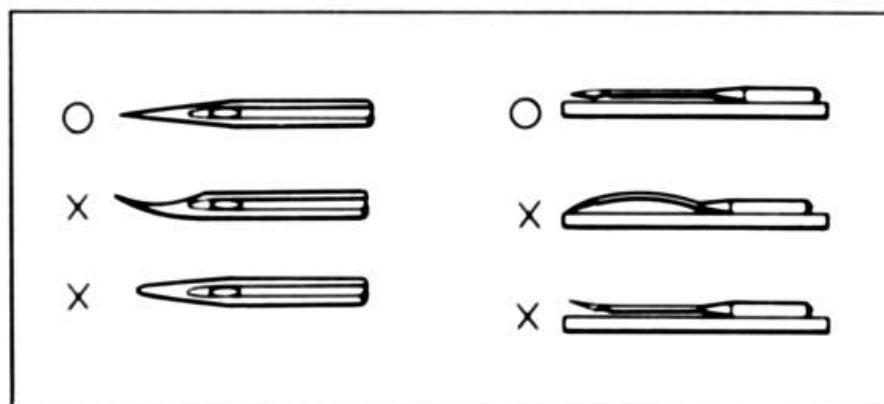

- 1. The sewing needle must always be straight and sharp for smooth sewing.**
- 2. To check if needle is bent, place flat side of needle down as shown in illustration at right.**

Changing the bulb

- Remove the power supply plug from the outlet.

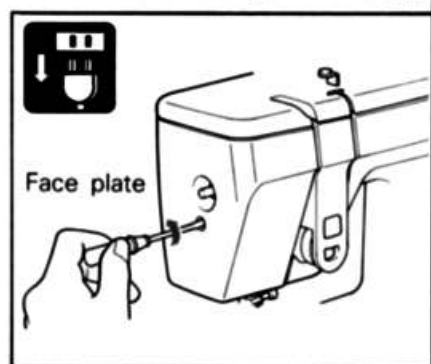

1. Loosen the screw.

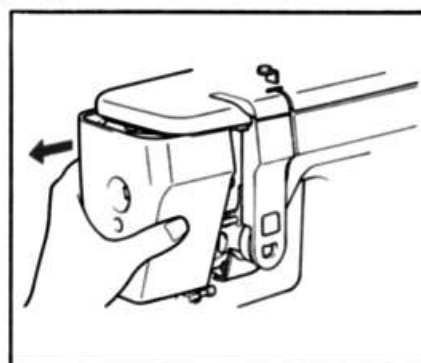

2. Remove the face plate from machine.

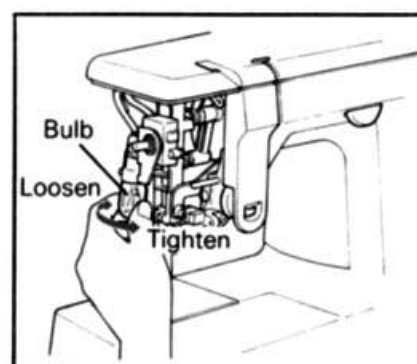

3. Replace the bulb.

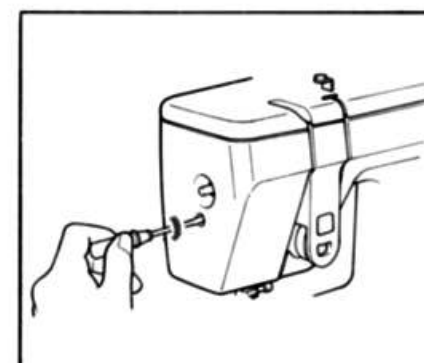

4. Attach the face plate and fasten the screw.

Cleaning

- Remove the power supply plug from the outlet.
- Lint and dust easily accumulate. Always keep clean.

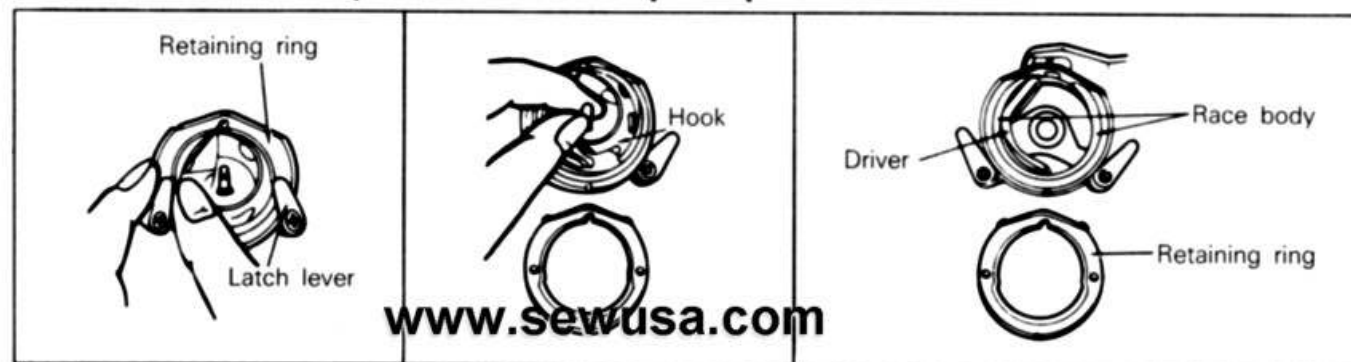

www.sewusa.com

HOW TO REMOVE THE SHUTTLE HOOK

1. Raise the needle to its highest position.
2. Open the shuttle cover.
3. Take out the bobbin case.
4. Push latch levers outside and remove the retaining ring.
5. Remove the hook by grasping center post of the hook.

NOTE: When needle is lowered, shuttle hook cannot be removed.

CLEANING SHUTTLE RACE

1. Remove accumulated lint and thread from the retaining ring, hook, driver and race body with brush.
2. A cloth dampened with machine oil should be used to wipe shuttle race clean.
3. Clean shuttle hook in same manner as above.
4. Reassemble and push the latch levers inside.

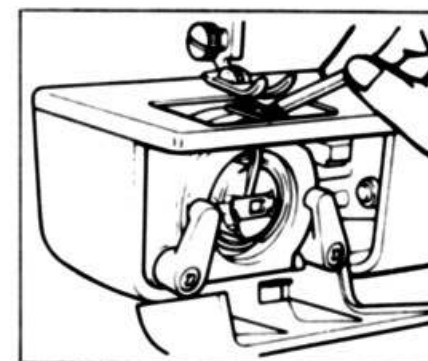

CLEANING FEED DOG

1. Take out the needle plate.
2. Clean the upper part of feed dog and shuttle race body with a brush.

Oiling

- Remove the power supply plug from the outlet.
- OIL ONCE A WEEK IF THE MACHINE IS USED MORE THAN ONE HOUR PER DAY.
IF THE MACHINE IS USED MORE OFTEN OIL EVERY DAY.

- OIL 2 TO 3 DROPS TO THE POINTS MARKED
- After oiling, run the machine fast without thread.
- Be sure to wipe off any excess oil.

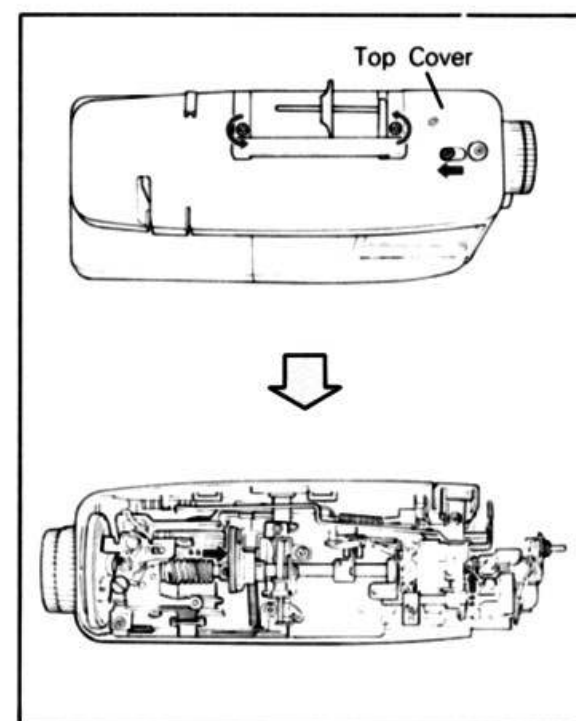
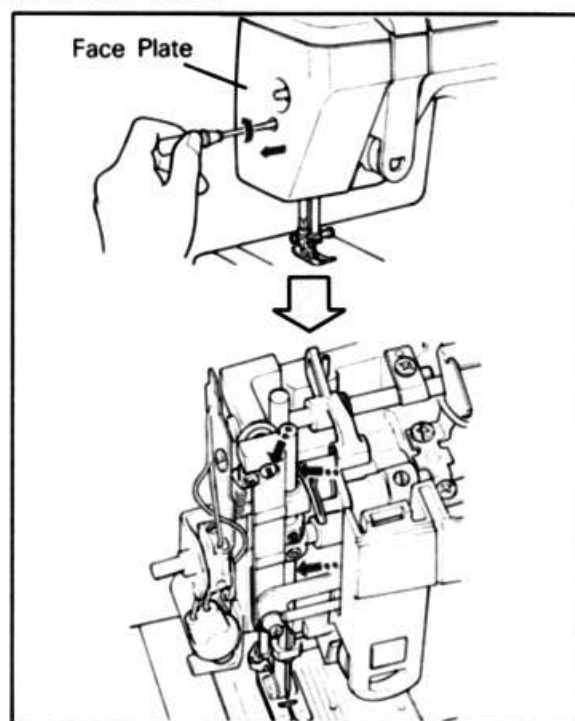
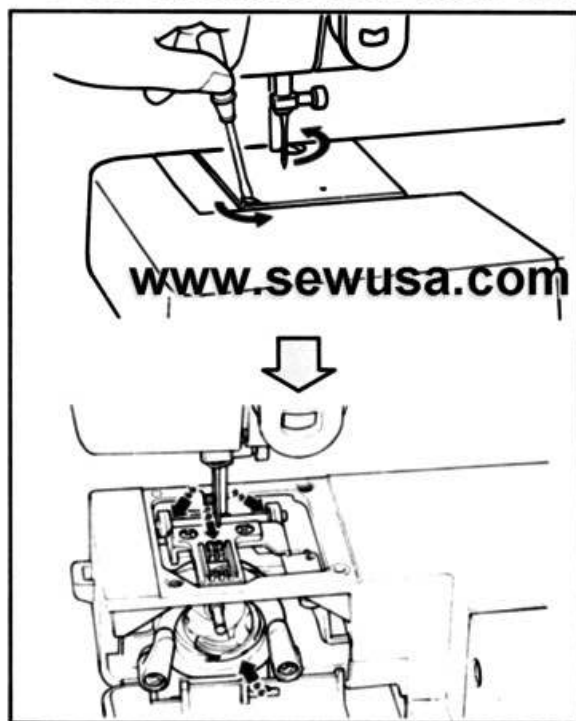

Performance check list

Whenever sewing difficulty is encountered, review the section of the instruction book that explains the operation you are performing to make sure you are using the machine correctly. If the problem still exists, the following check list may help you correct it. If you still have difficulties, contact your nearest service center.

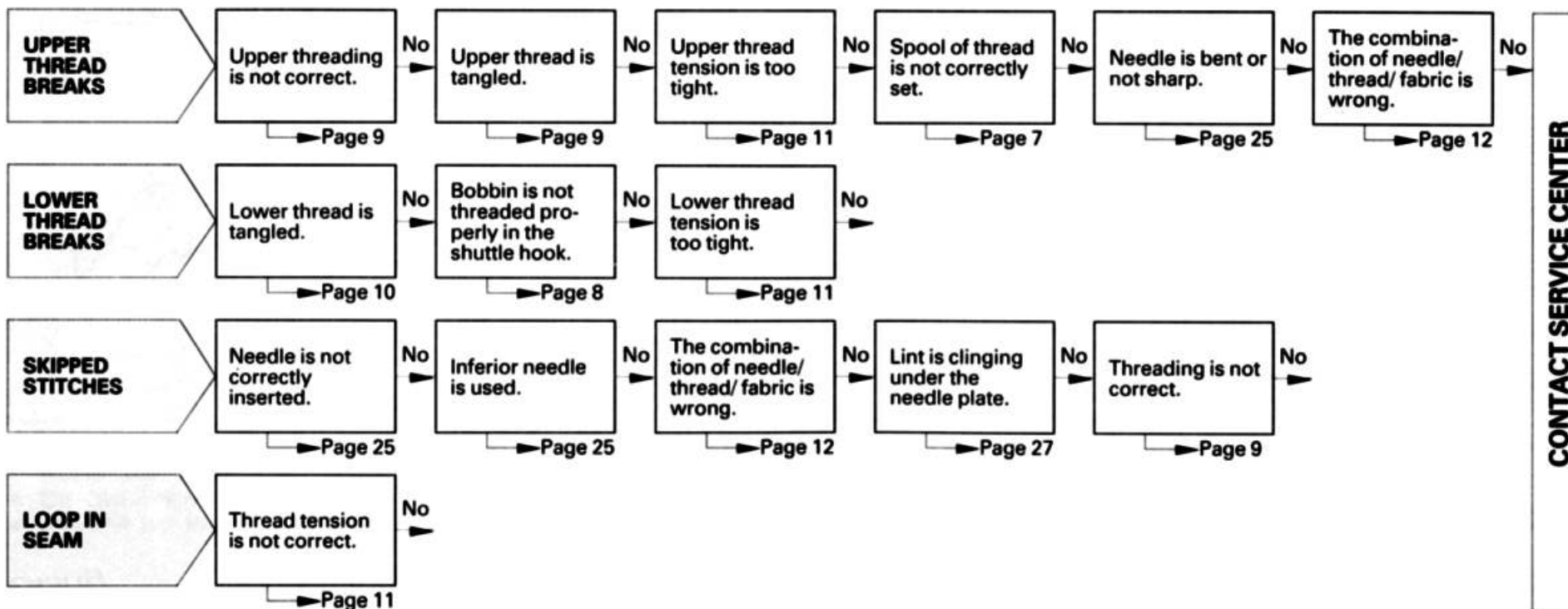

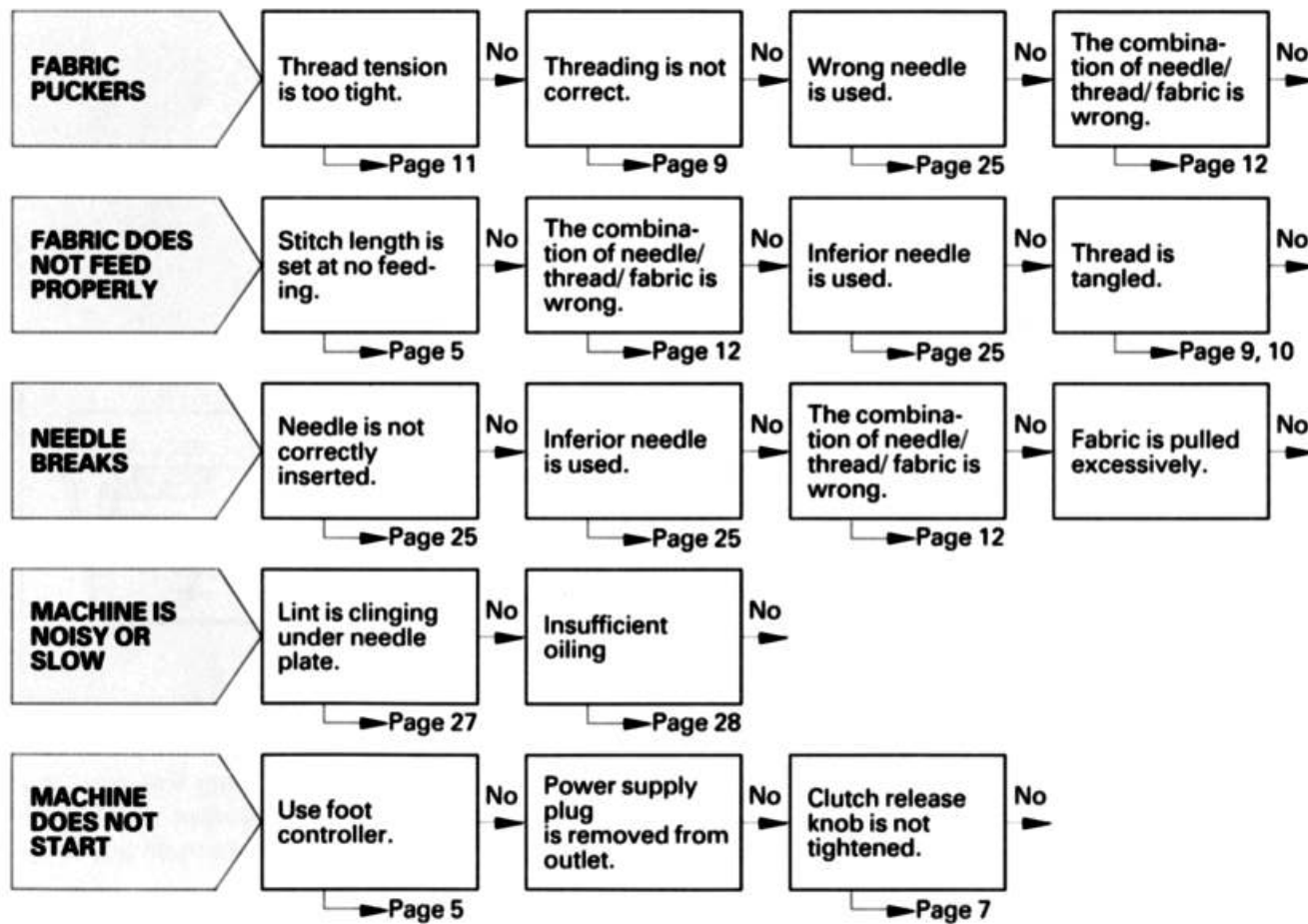

CONTACT SERVICE CENTER

Repacking the machine

Keep the carton and packing materials for future use when it is necessary to reshipe the sewing machine. Improper packing or improper packing material could result in damage during shipping. Instructions for repacking the machine are illustrated below.

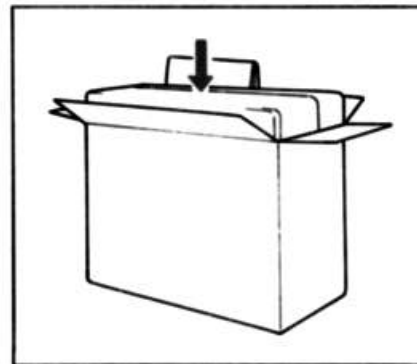
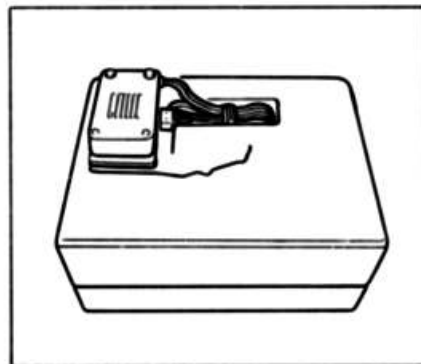
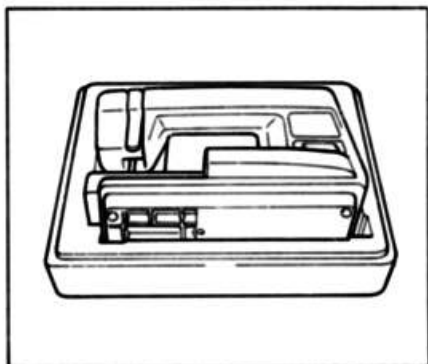

IMPORTANT

This packing material is designed to prevent damage in transit. Save this packing material in the event you need to transport this sewing machine.

INDEX

	Page
Accessories	2
Applique	23
Blind hem stitch	16
Buttonhole	19
Button sewing	21
Changing the bulb	26
Changing the needle	25
Cleaning	27
Darning	23
Draw up lower thread	10
Elastic stitch	18
Foot controller	5
Free-arm model	6
Lower threading	8
Monogramming and embroidering	24
Oiling	28
Overedging stitch	17

	Page
Pattern selector	3
Performance check List	29
Principal parts	1
Relative chart of sewing fabrics, needle and thread	12
Repacking the machine	31
Reverse sewing button	5
Sewing-light	5
Stitch length dial	5
Straight stitch	13
Tension controls	11
Twin needle	6
Upper threading	9
Winding the bobbin	7
Zigzag stitch	15
Zipper insertion	22